

SEQUENCING:

K.S.



ERNST



sequencing

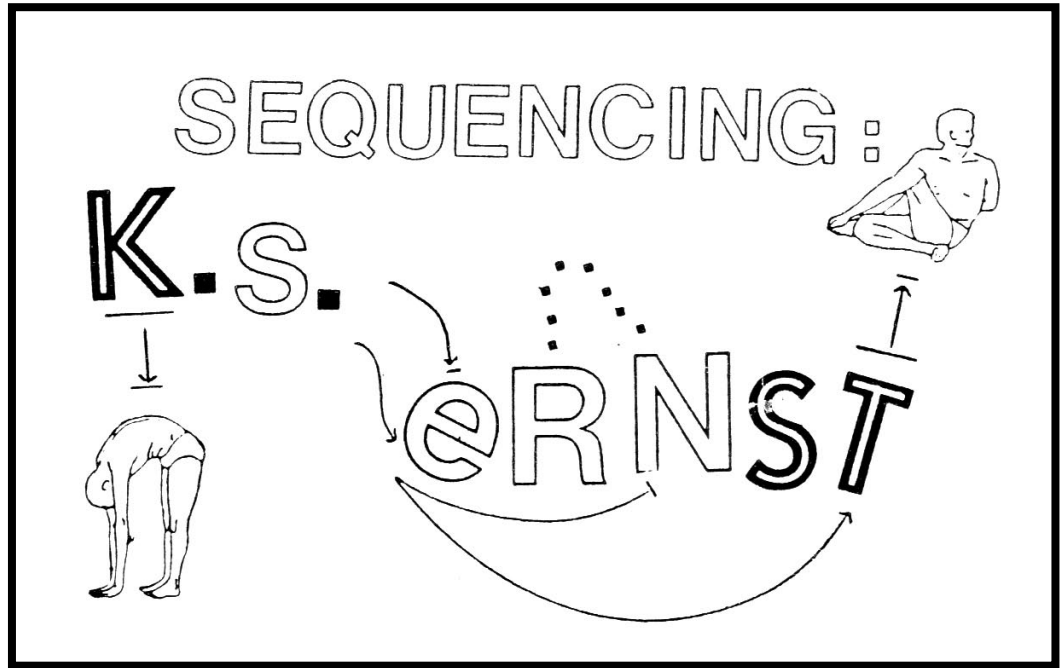

XEXOXIAL Editions • West Lima Wisconsin • 2008

SEQUENCING is available both as a flipbook anthology and as a deck of cards. Designed by mIEKAL aND & Elizabeth Was of Xerox Sutra Editions, February 1984. 3rd edition includes 21 pieces not included in previous editions. Digitized for posterity August 2008.

Some of the poems in SEQUENCING have appeared in the following magazines: Antenna, Appearances, Bikini Girl, The Fault, Kaldron, Look Quick, Lost and Found Times, Newrite, Sackbut Review, Salome, Swift Kick, Truly Fine, Woodrose, Score, and Visual Poetry in the Avant Writing Collection (of The Ohio State University Libraries).

© K. S. Ernst 1984, 2008

ISBN 1-4404-1447-5

EAN-13 978-1-4404-1447-3

published by
Xexoxial Editions
10375 County Highway Alphabet
La Farge, WI 54639

www.xexoxial.org

perspicacity@xexoxial.org

"I am interested in words and letters as symbols - not in some mystical way, but in a very literal way. A spoken word is just noise and a written word is only a marking, both meant to represent something else. Words provide a vehicle for one person to attempt to describe his perceptions to another. This act, though, is at best an ephemeral and incomplete one due to the nature of language. People build houses of cards with words, then go about knocking each other's down on the basis of which cards they used, rather than what perceptions they intended to convey. I am interested in the basic symbolic make-up of words as well as their representational use. This is probably more obvious in my three-dimensional work than in my work on paper, but SEQUENCING poems are as close as I can come to putting three dimensions into two."

K.S. ERNST

Aug 22, 1983



NEW JERSEY TURNPIKE

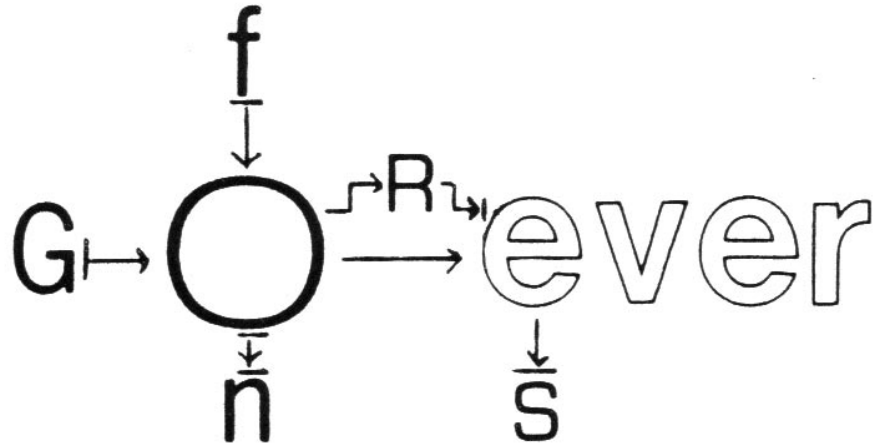

PROSERPINA

I HAV E
COM E

Wh ^rEE is
my C ^LEE B R A
tion

MOLIÈRE

HIS T b
 | |
 | e R M S
 | | E
A L L V
 | | ong

A GLANCE

WHO are U

ACROSS THE BORDER

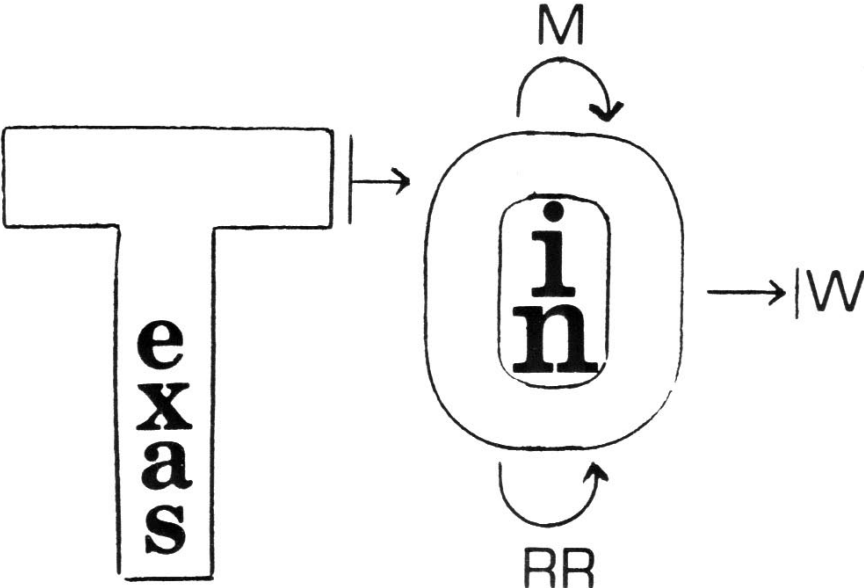

WHERE WE LIVE

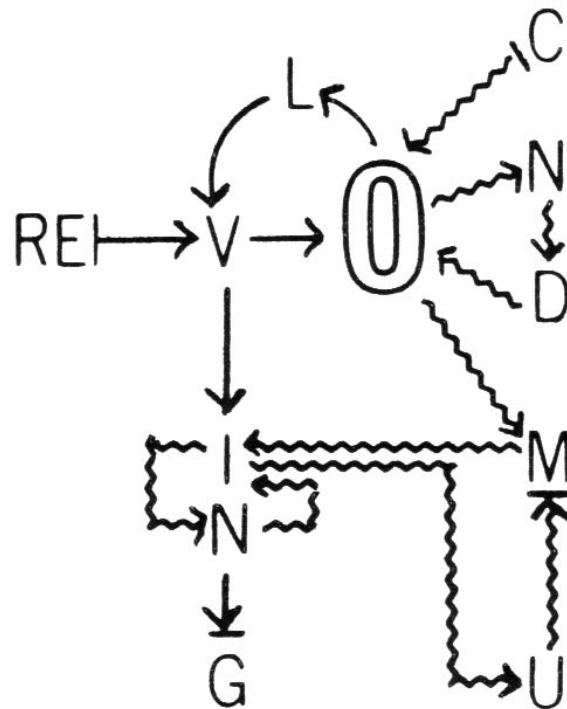

THE COP

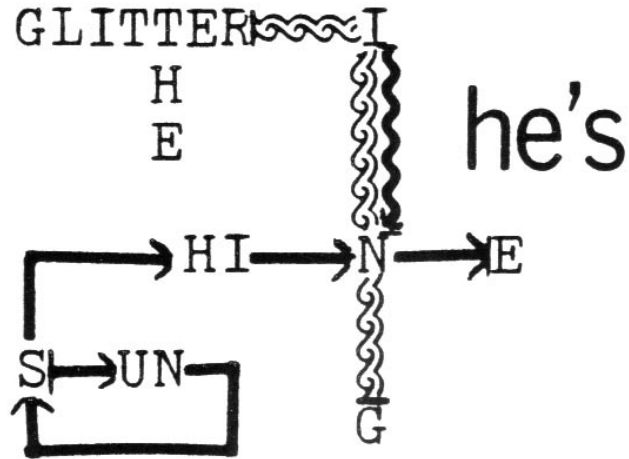

PHYLLIS

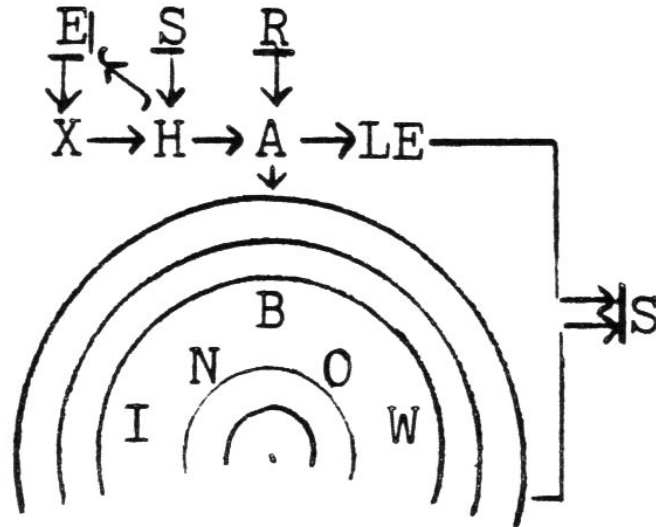

ROBIN

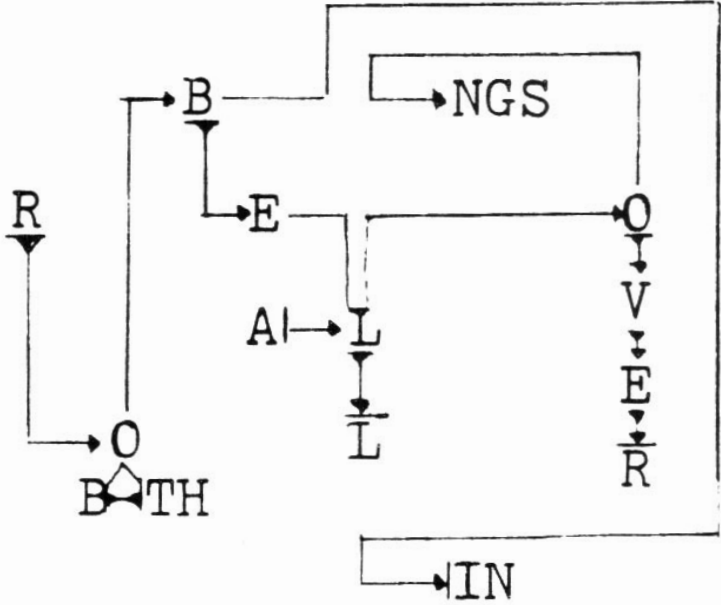

MARCUS

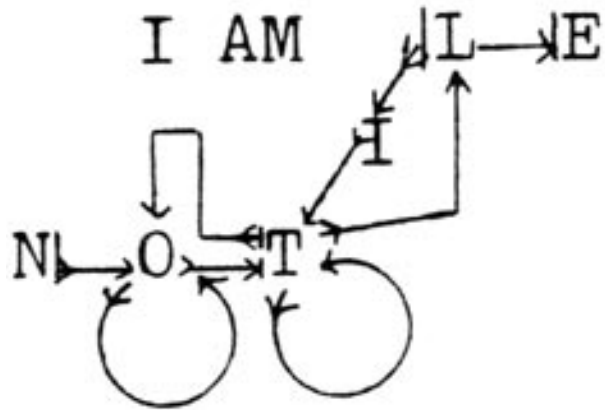

VERLAINE

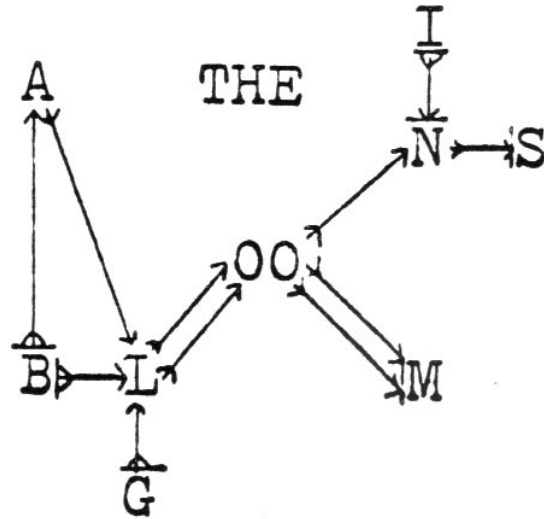



I MUST HAVE BEEN

A

D

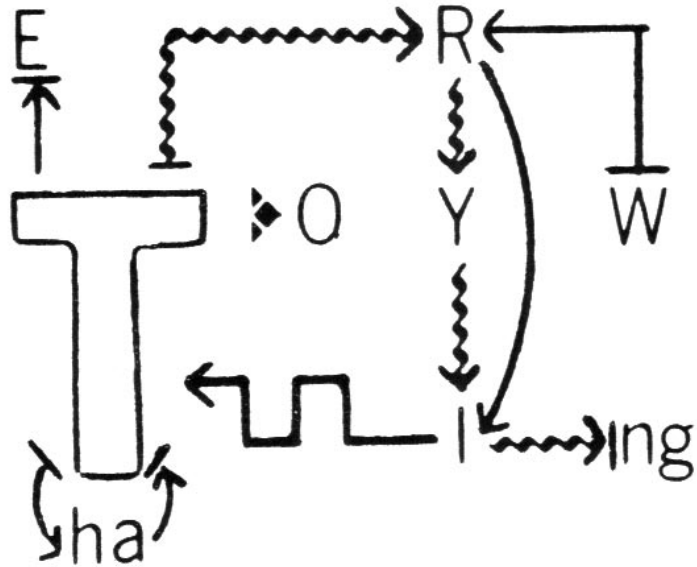

PLAYING CHESS

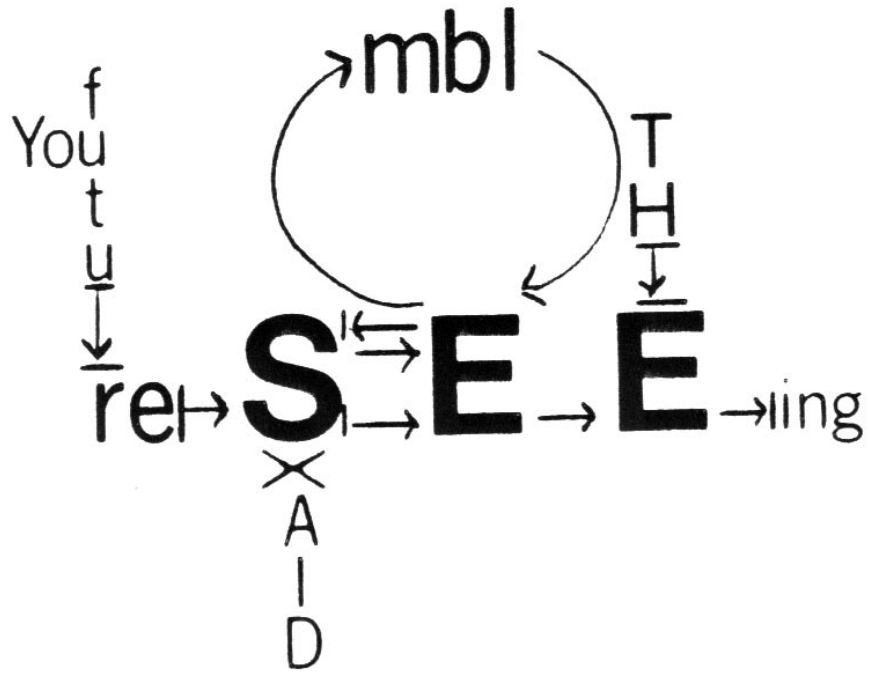

YOUR PLEASURE

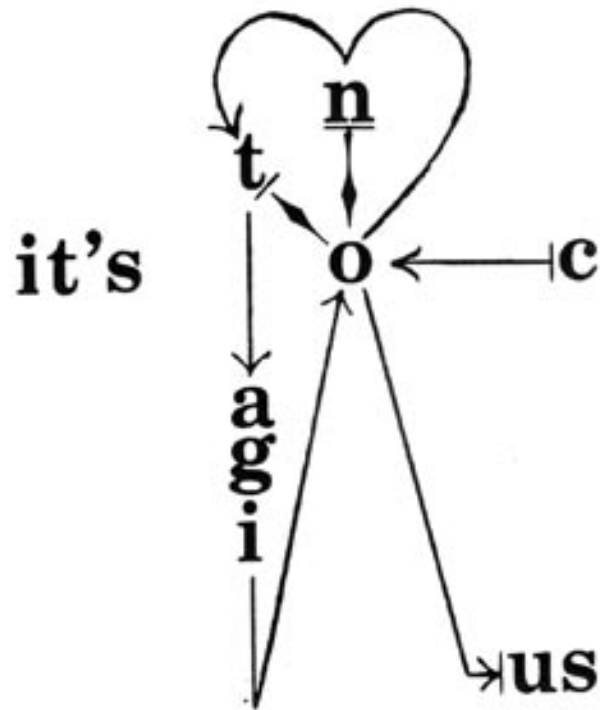

YOUR SECRET LIFE

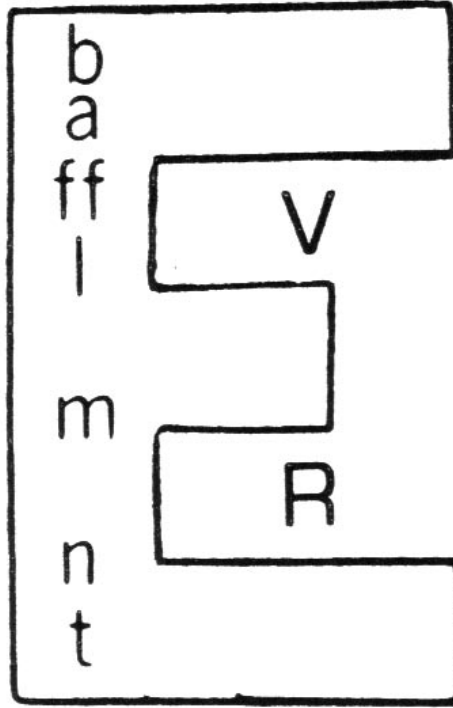

↙ n
d
i
n

AL, LAUGHING

we

H A N D
L E
C N th m

HOLES

BECOME
THEM
FALL
IN

WHEN I DANCE

my **F** **E** **A** **R**
k **E** **E** **T**
ps

the **gr** **O**^u **N** **D**

A BLIZZARD OCCURS

TO
I
the CAUSE
R
x
x
x
x
x
x
x
x
x
T
H
B

THE AUTUMN MOON

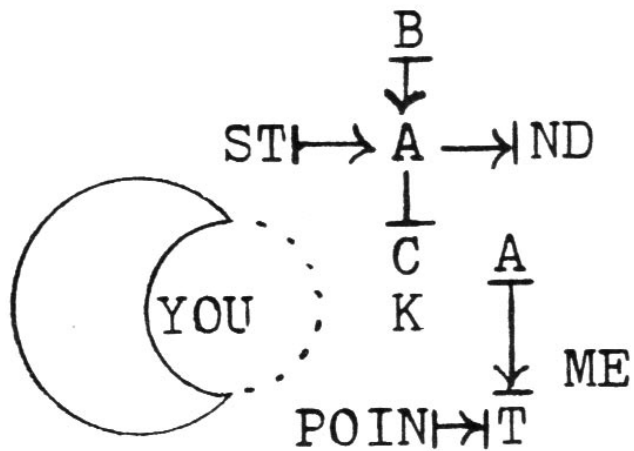

SUMMER

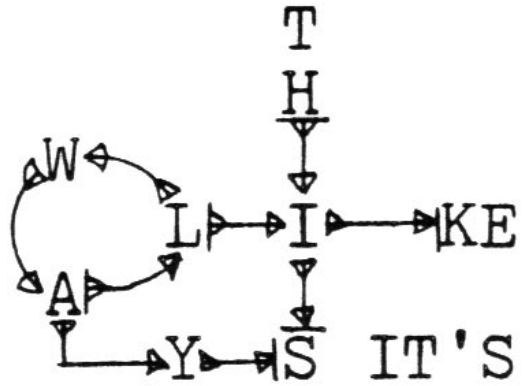

AUTUMN DRAWS

TO A CLOSE

~ I ~ R E A C H ~ I ~
 O U T
 I
 K

G O T I T !



NOTHING IS RESOLVED



MY TRAIN OF THOUGHT

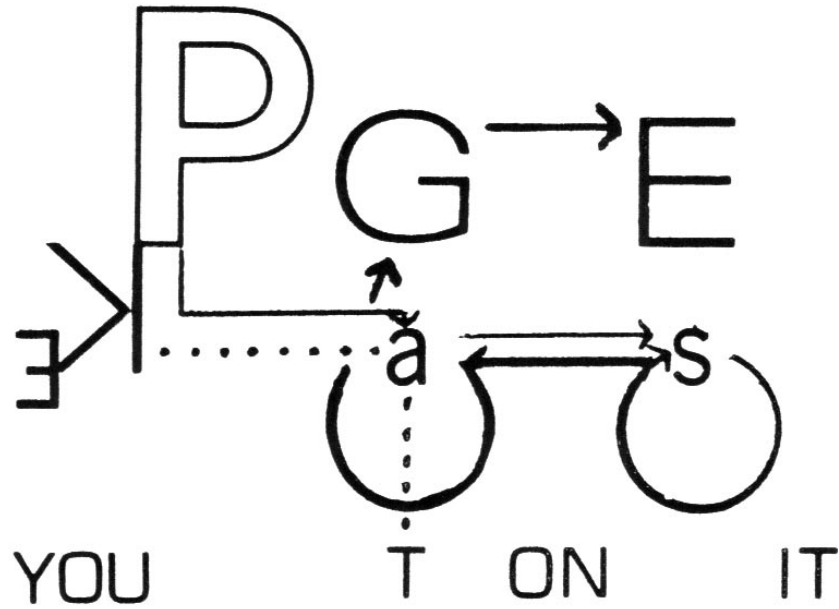

DO YOU KNOW



REAL LIFE

it C be
FAN
T S
i C f

the y u IG Have
WORT
ds

INSPIRATION

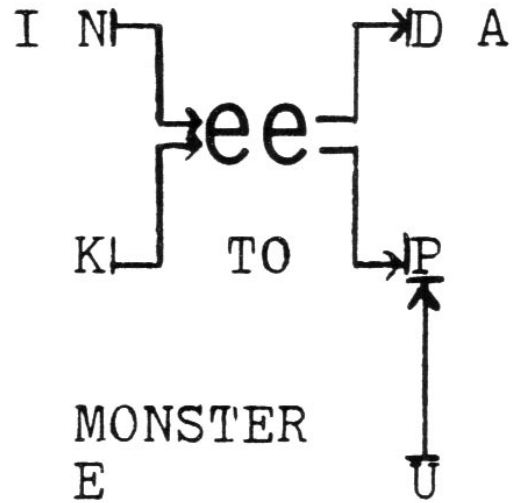

rites

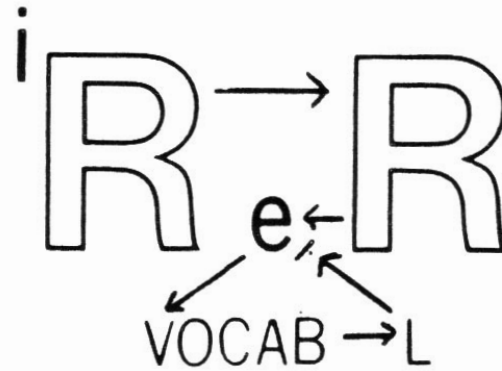
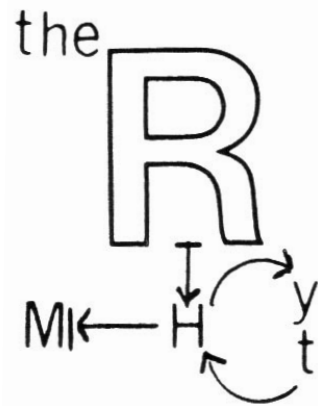

THE HUMAN BRAIN

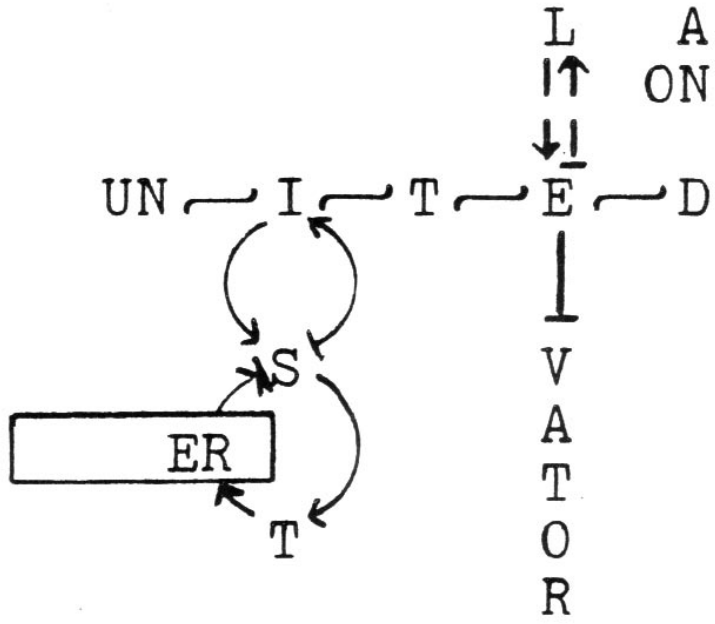

BASIC HOPES

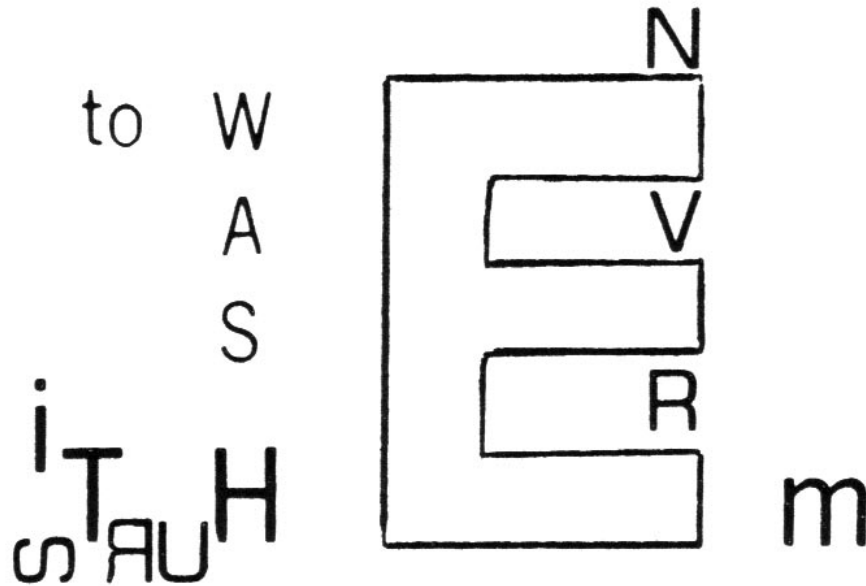

A PHAROAH

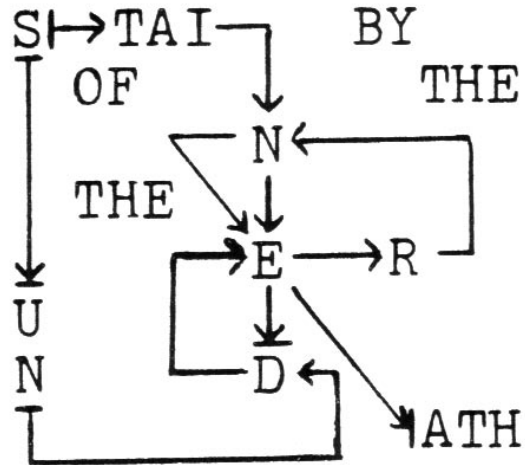

PHILOSOPHY

Th
in Kn O ugh TS

THE FUTURE

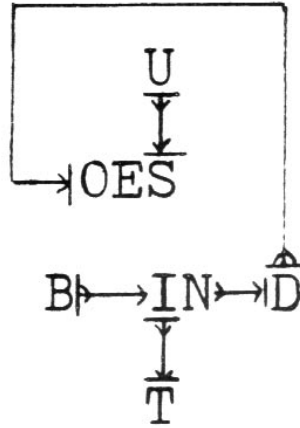

ILLUSIONS

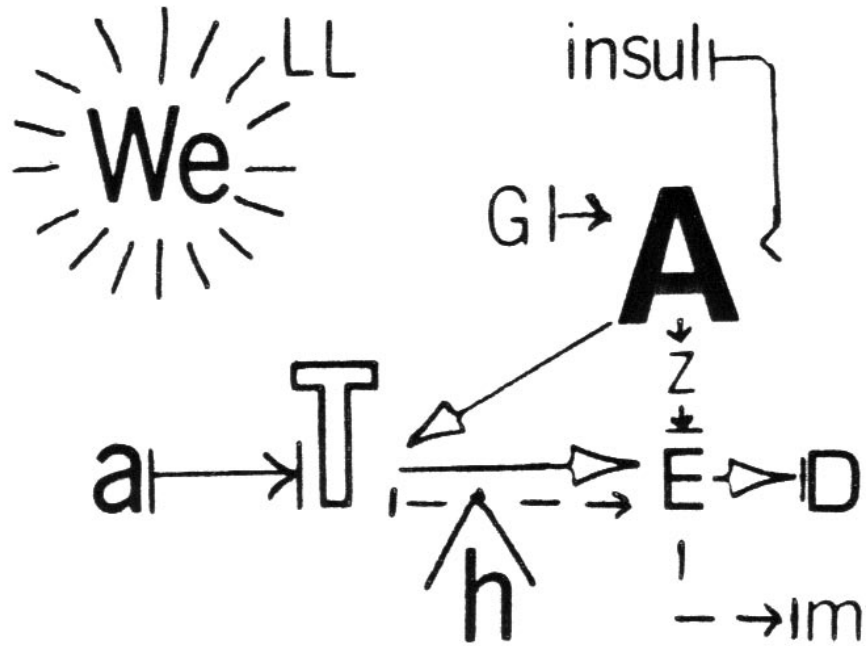



CORBIN'S CHORD

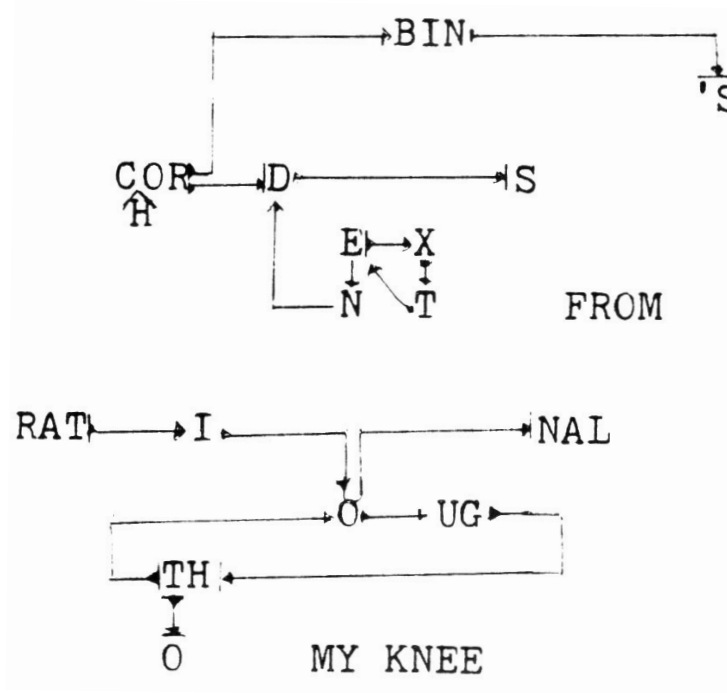

THE OCEAN

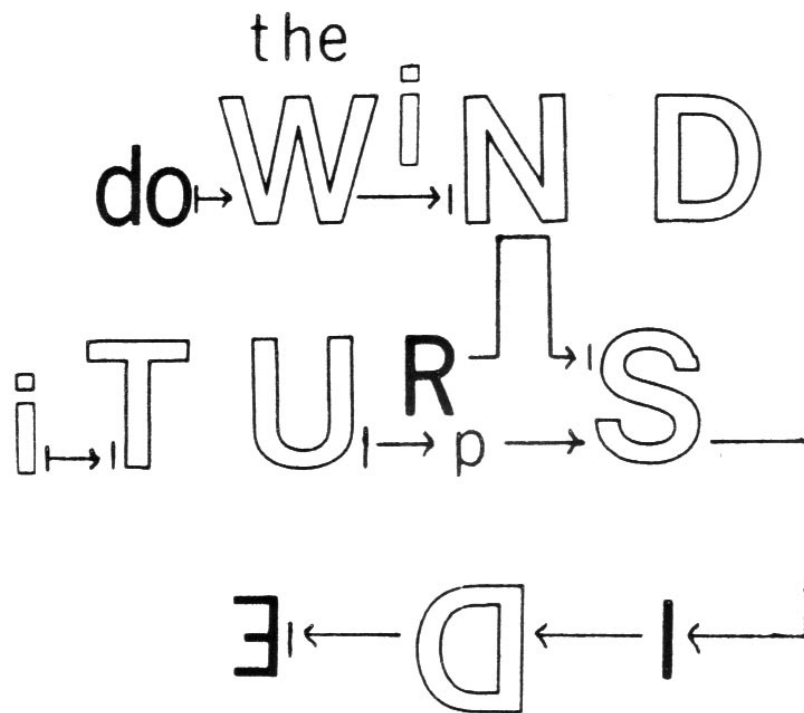

LIGHTNING

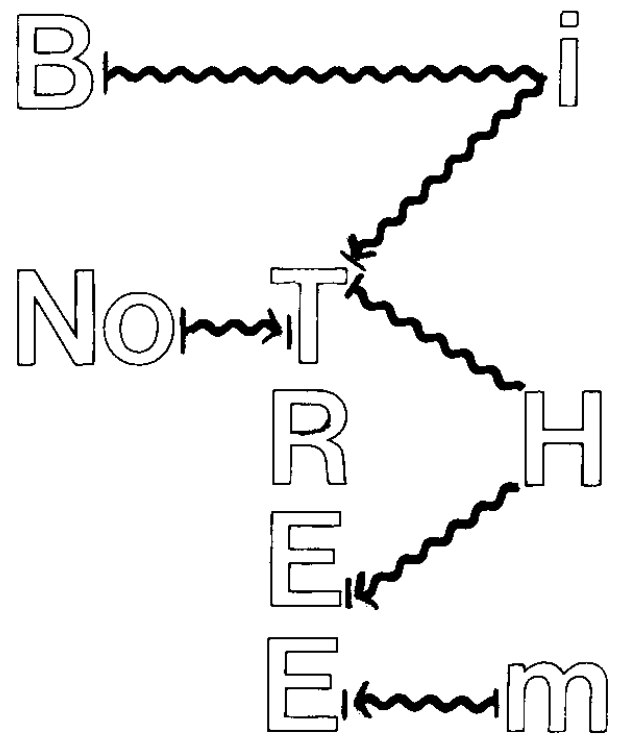

TIME ON MY HANDS

FINE_S

yo
P U T H E M
RE

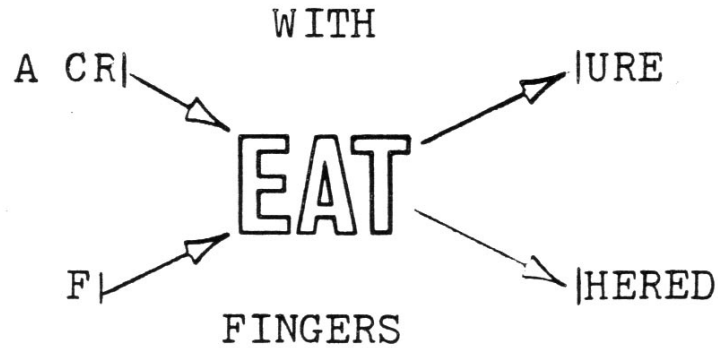
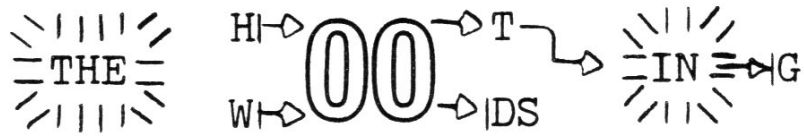

TIME LIGHTS A FIRE

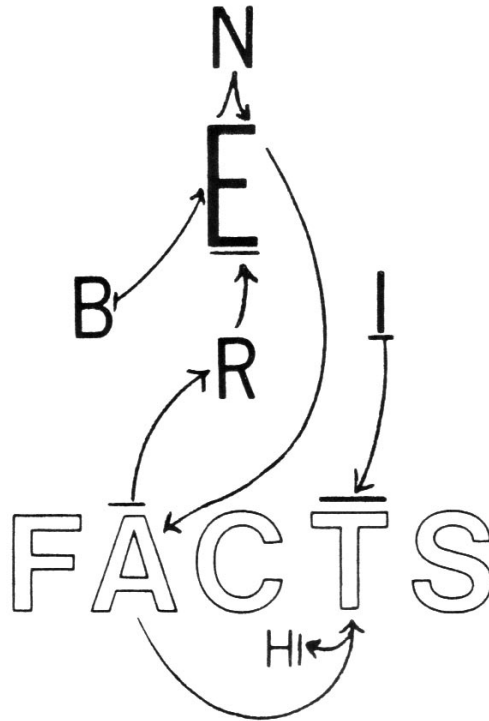

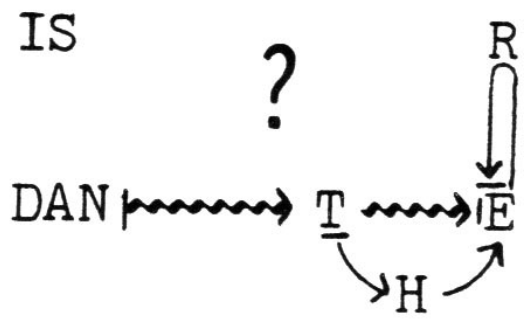
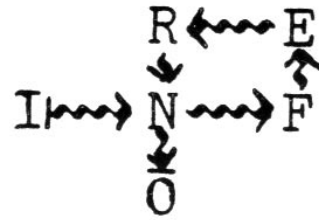

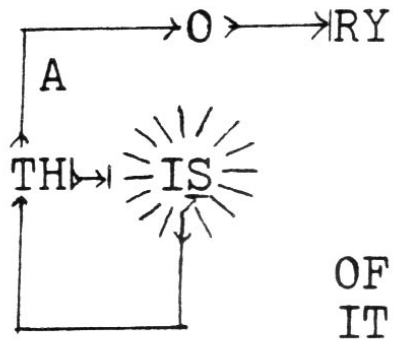
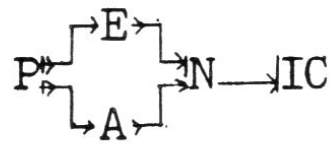

OF
IT

?

DIANA

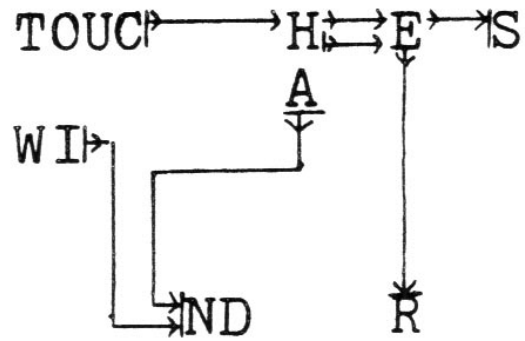

THE SEA

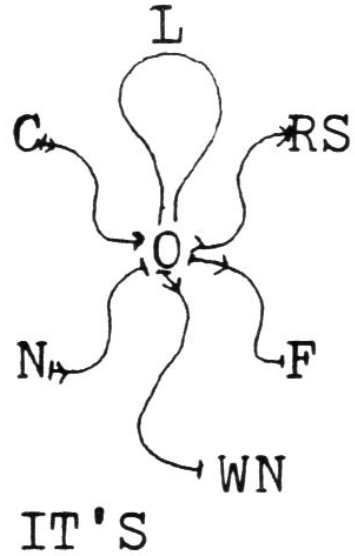

TOMB

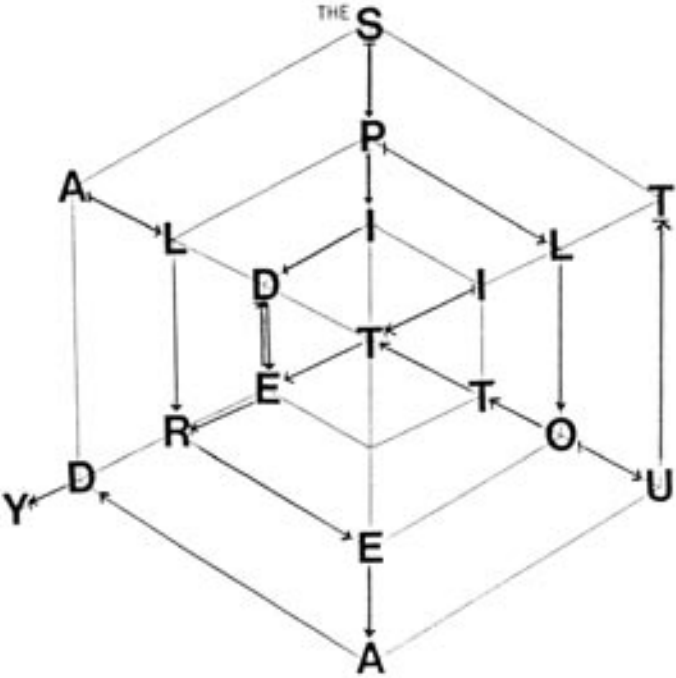

THE BROOK

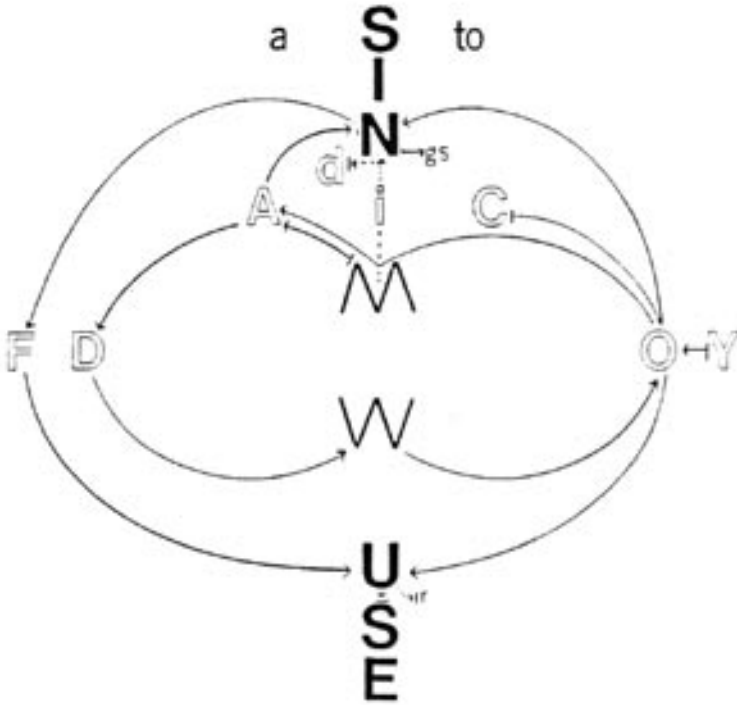



COMPUTERS

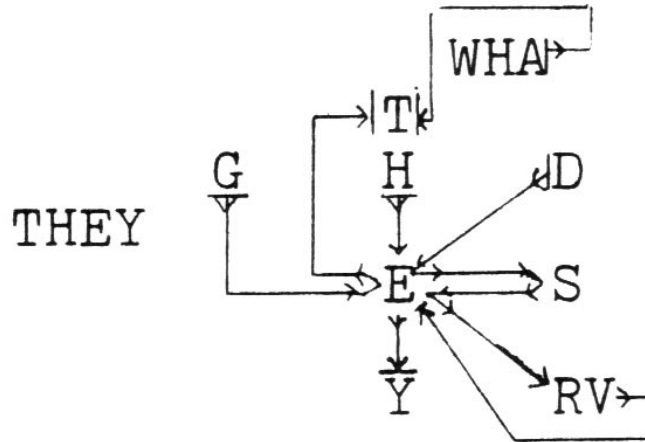

PARTY

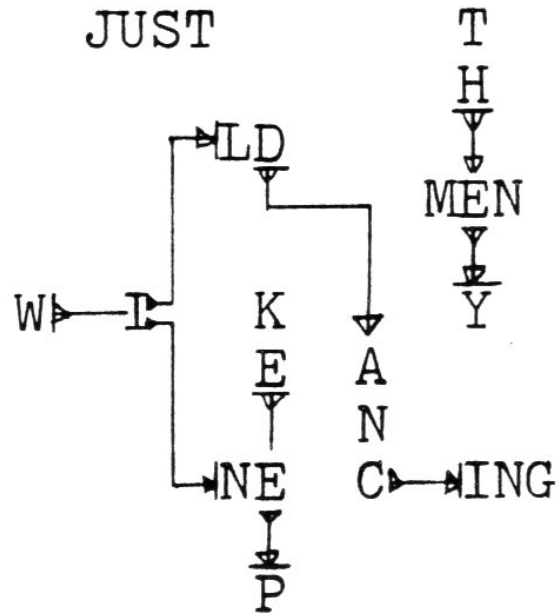

TURKISH TWINS



A C C O R D I A N

MOLLYTALK**K**SLIKEONE

DINING OUT

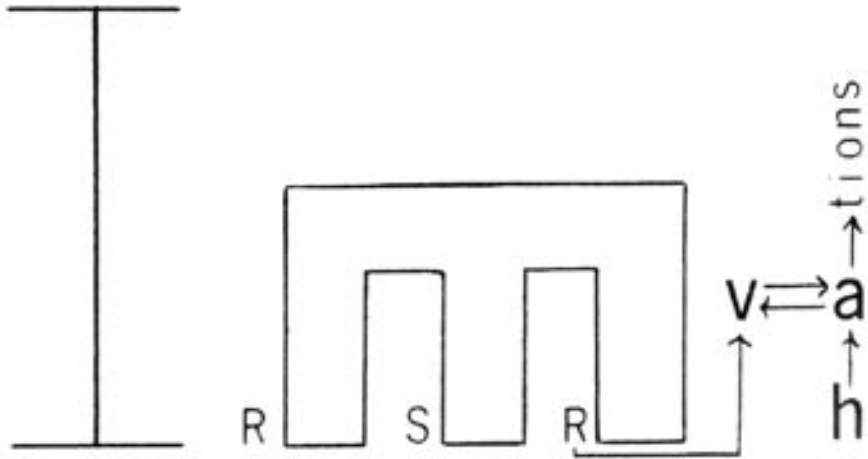

TEA

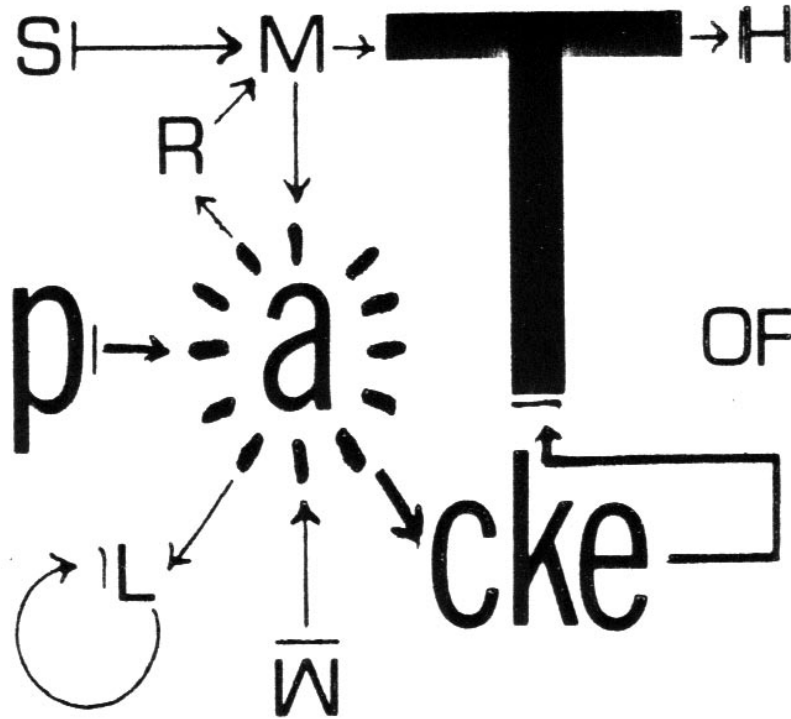

WILD GEESE

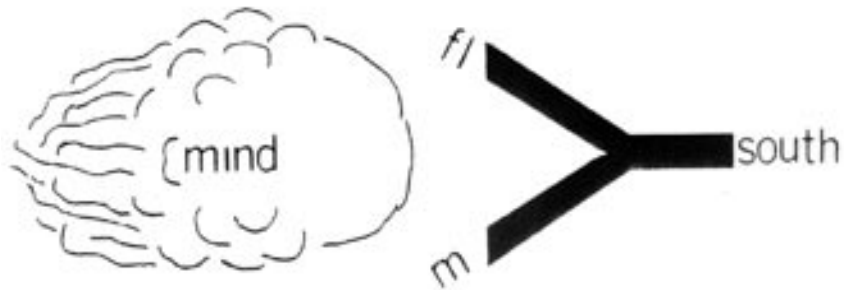

MY FINGERS POINT

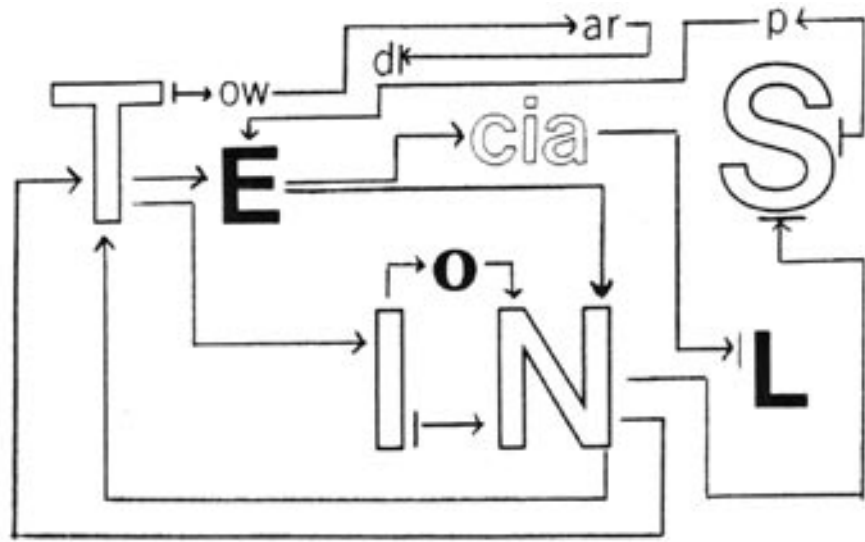

A TOMATO

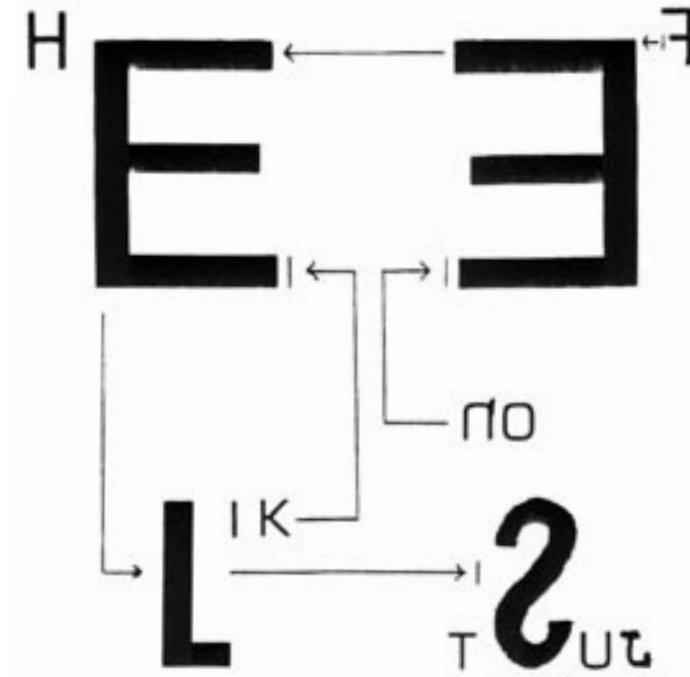

JUNK FOOD

can't

Tune

FUR
YOU

Little

get

that

GILA MONSTER

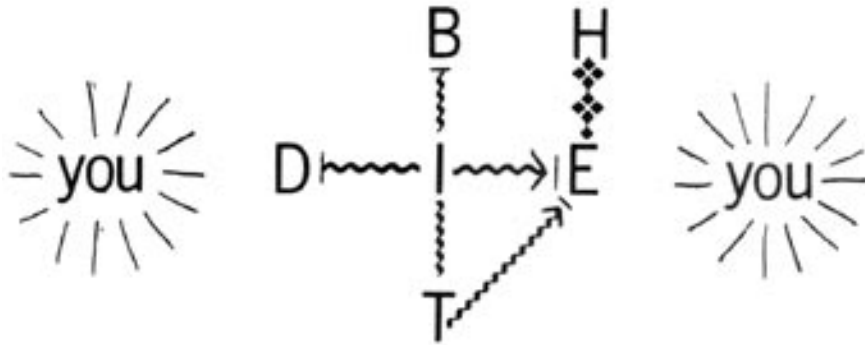

A VIABLE EGG

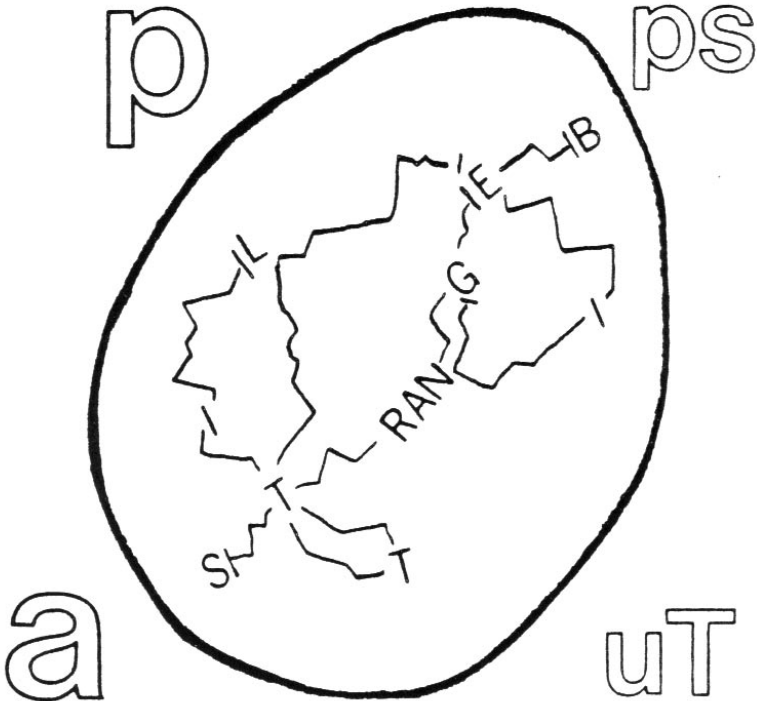

MY FINGERS

I L E T do
M ← E ← H

TH^e → IN → K
→ G

A BLACK EYE

CLA  M
t's

ART

THE POSTCARD

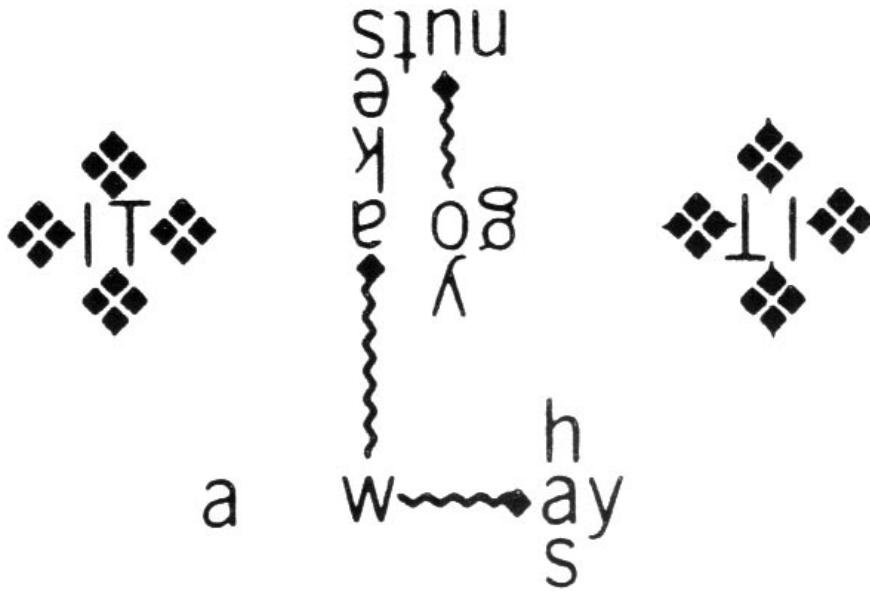

STRANGE DOGS

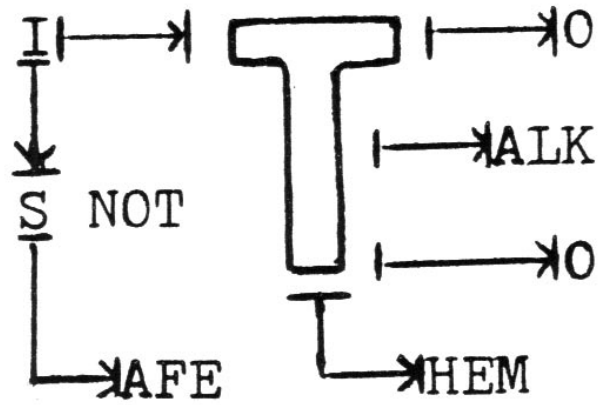

A SILVER CAT

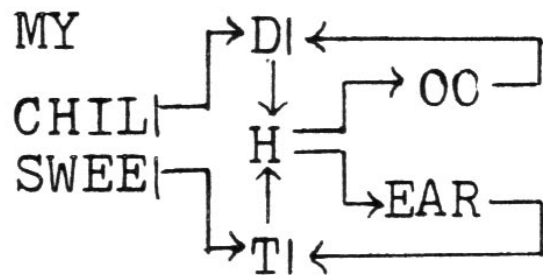

THE SIMIAN

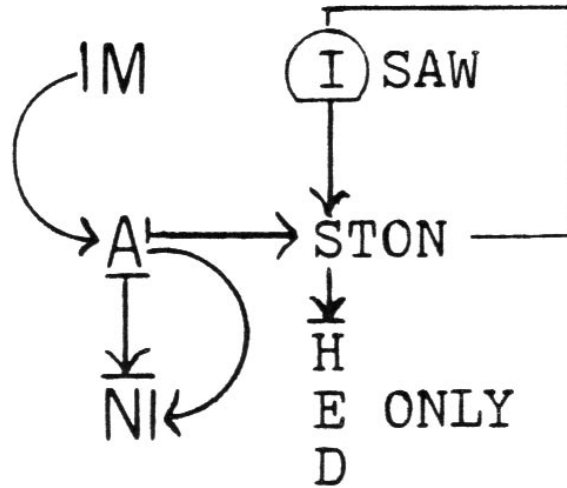

TASTE

ALWAYS

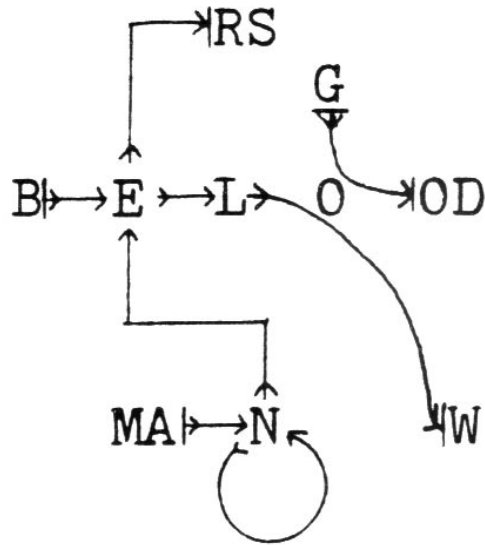



ODIOUS

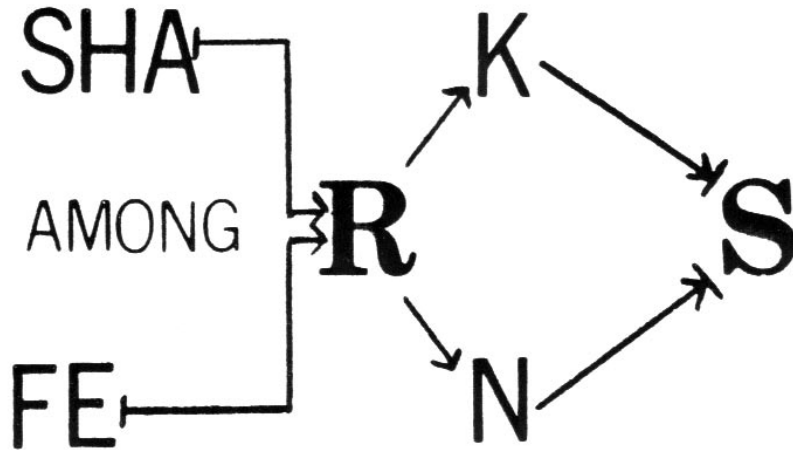

A COMFORTABLE CHAIR

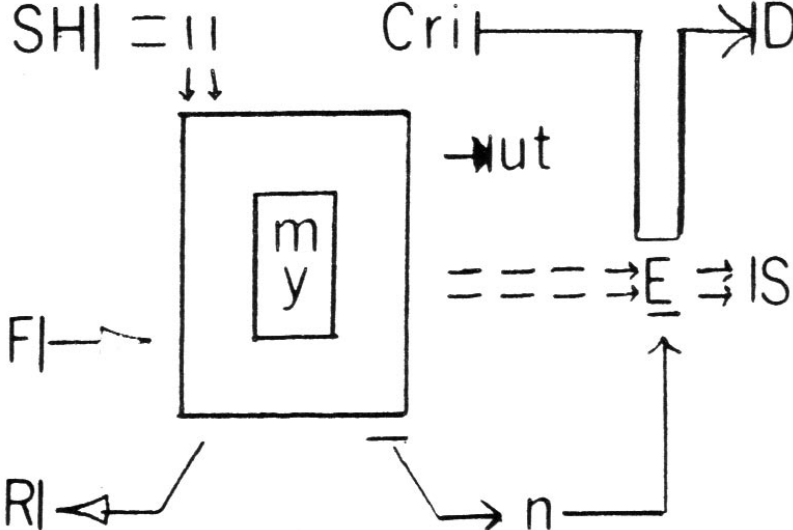

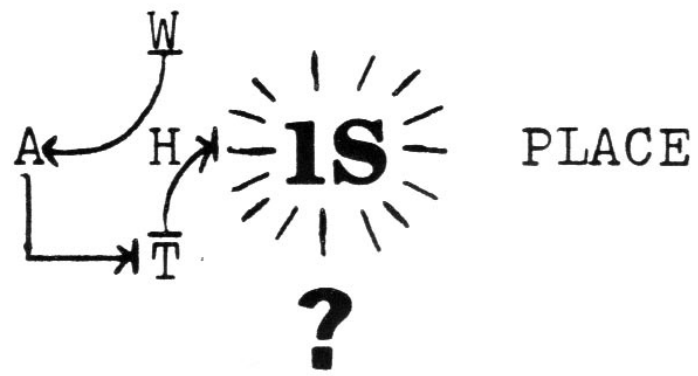
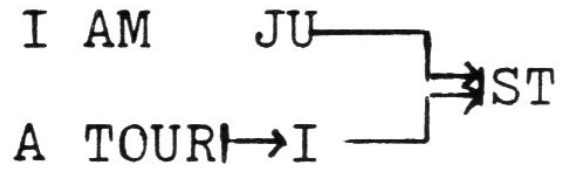

WARNING

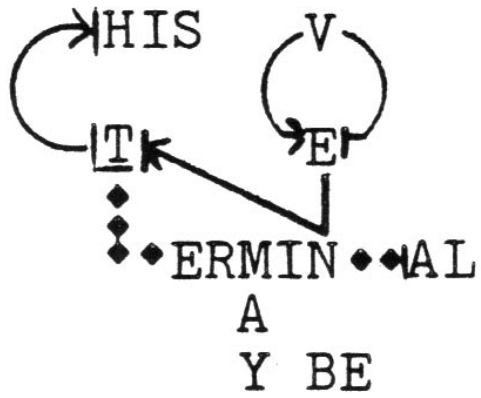

**T
O
LONG DELAYED**

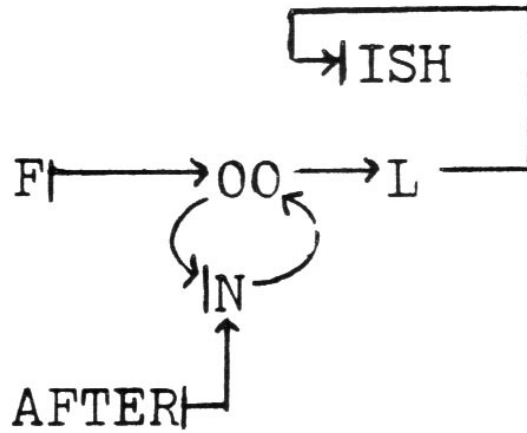

DE CRAZY MAN

S
P
H → E ← M
a
k

t
h
W H TH S
g
h
s

THE TAKE

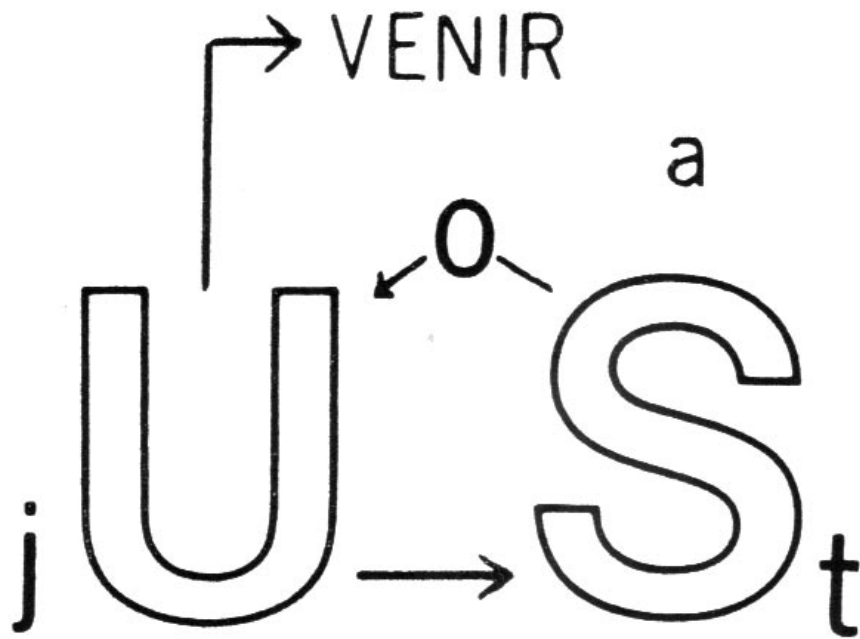

MAIN STREET

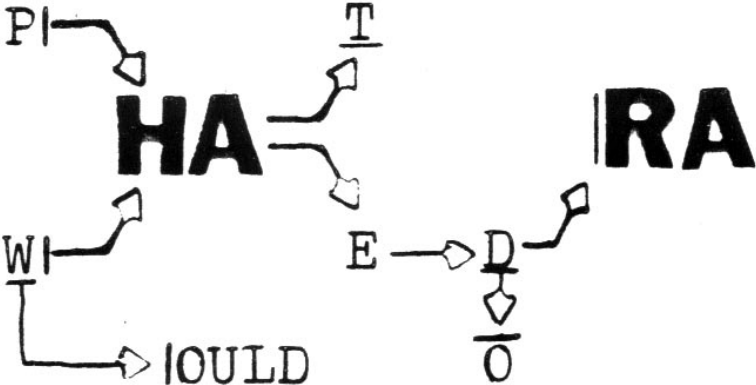

AM I CRAZY?

Yes

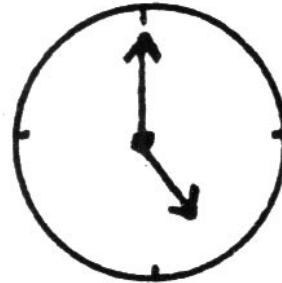
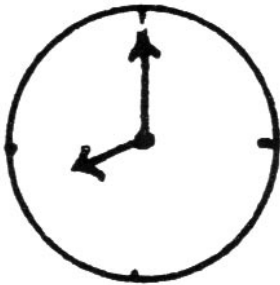

No

SNAKES

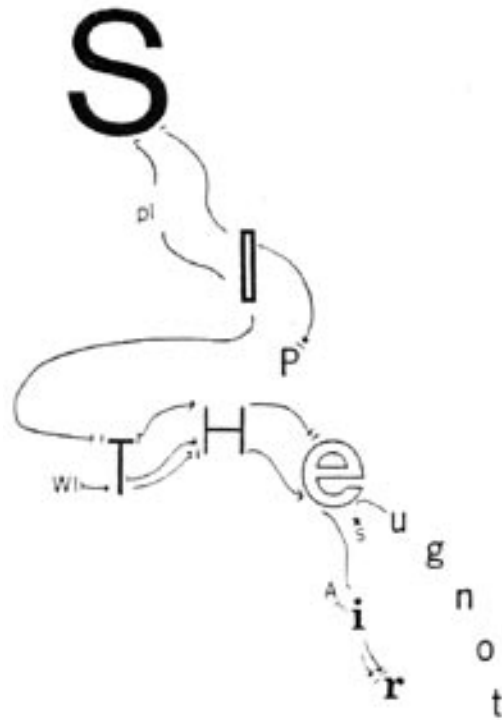

THE PARKWAY AT 4 a.m.

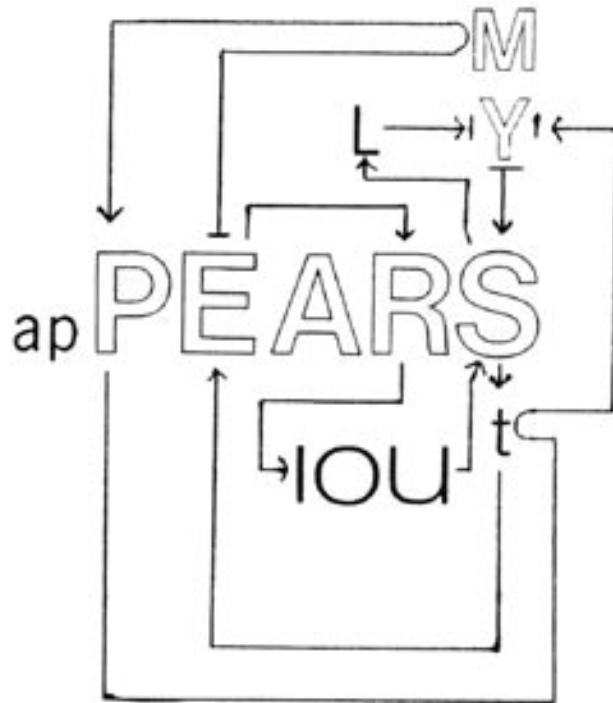

THE PILLOW WHERE YOU LIE

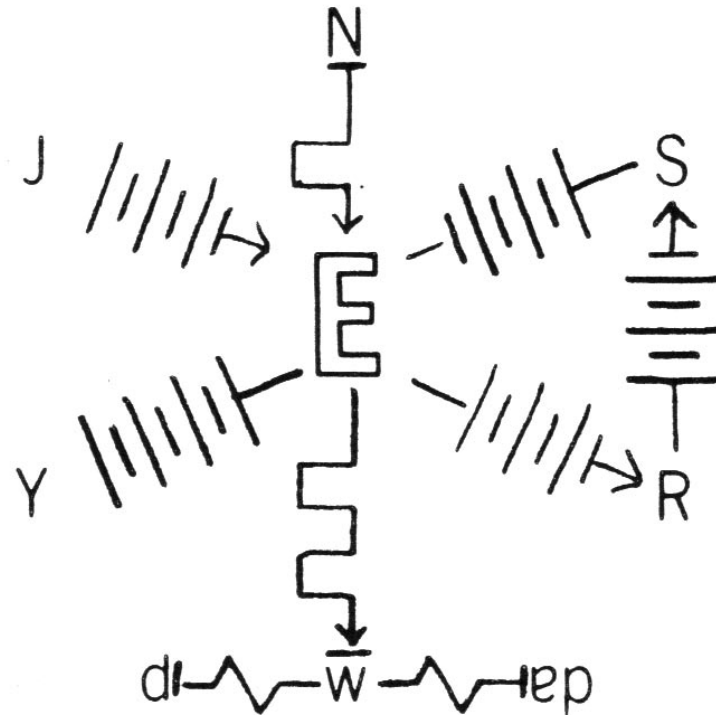

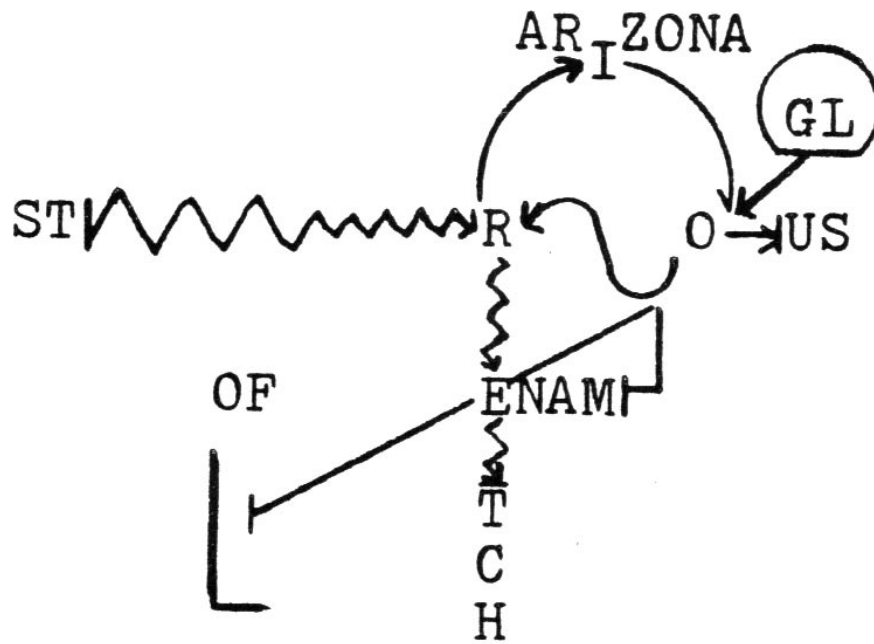

THE MISSING ONE

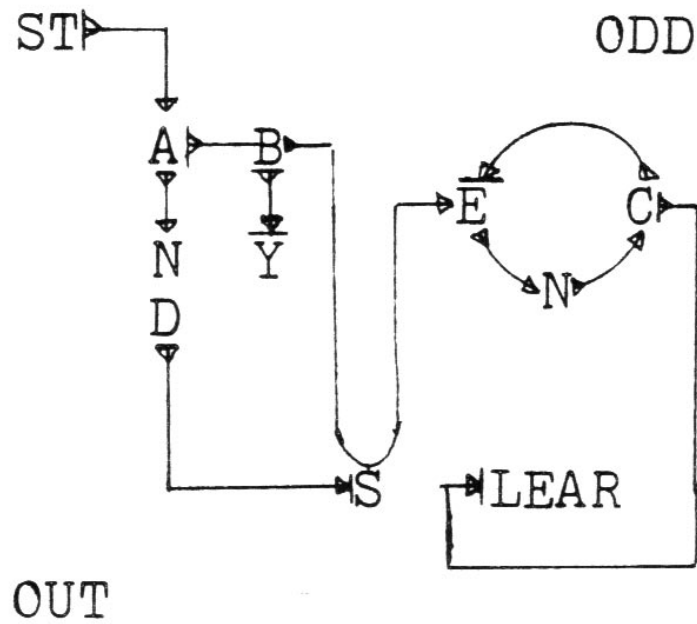

A CROSSROADS
WHERE....

S → UR → P → RISE
 H O
 Y I
 L
HLLIM
EXACTLY
S

JUNE

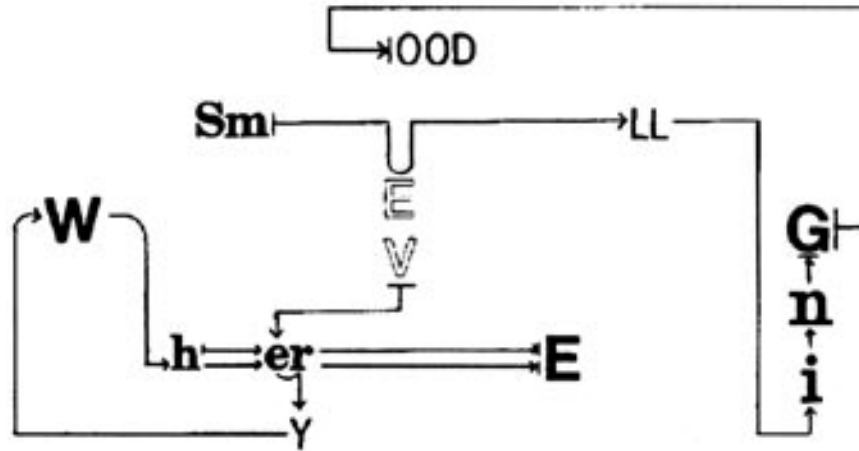

JANUARY

JUST

C

far

OLD

its

THE HOOTING IN THE WOODS



WITH



FINGERS

**H
O
STUFF**

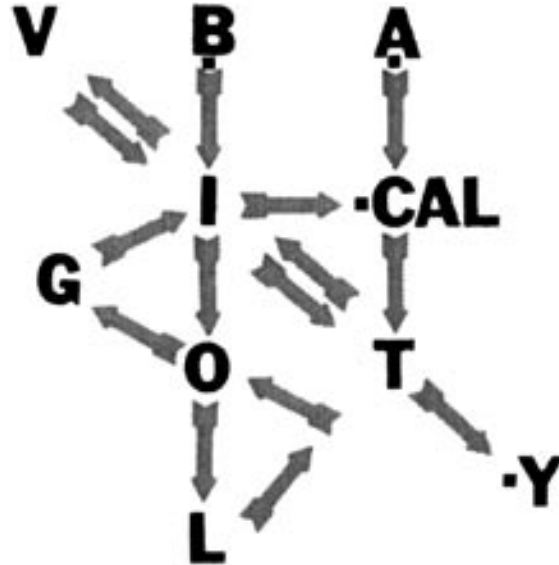

**AUGUST DRAWS
TO A CLOSE**

♦ I ♦ R E A C H ♦ I ♦
 O U T
 I
 K

G O T I T !

THE ALCHEMIST

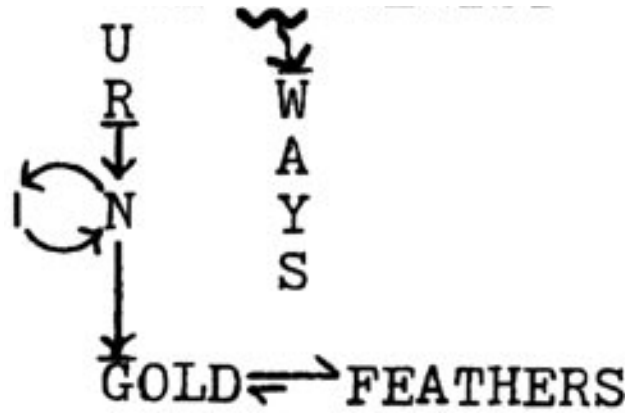

FOUNTAINS



PROGRESS

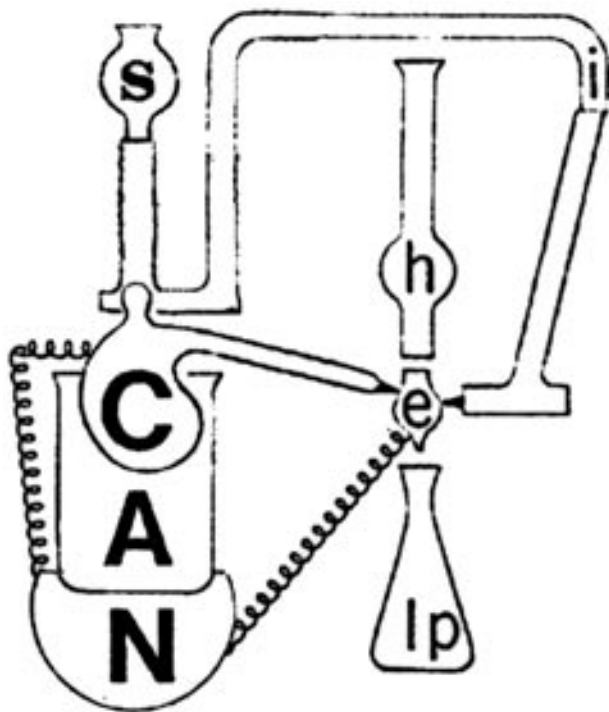

MY SHIRTSLEEVE

IN LOVE

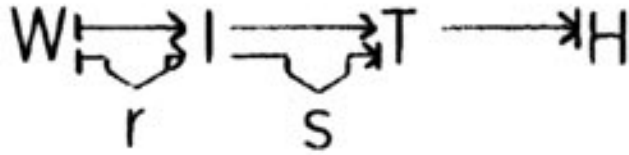

my

YOUR PARTS

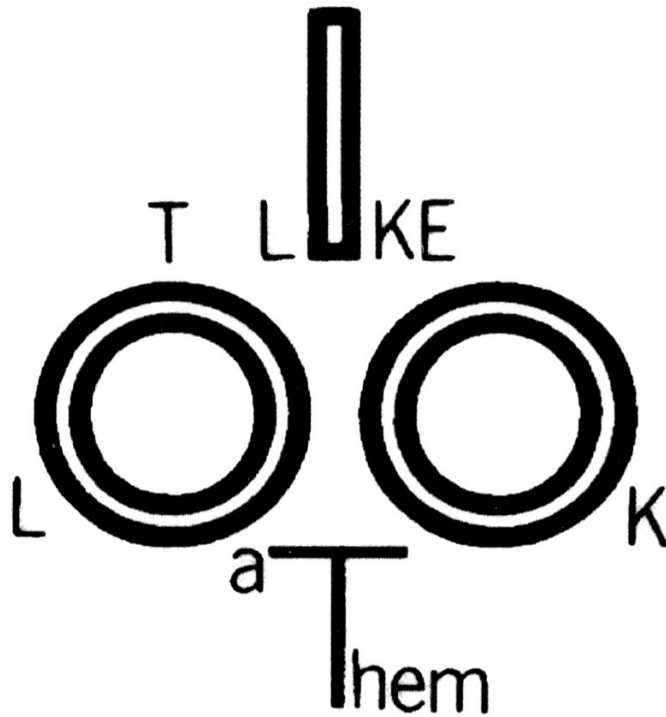

HIS MOTORCYCLE

M st ONE ^R
y
e
d

DO YOU LOVE ME?



MY
LOVE
Y
cle
R

I GOT REAL MAD

K th **E** **D**
ick **E**
S A N

HARLEY-DAVIDSON

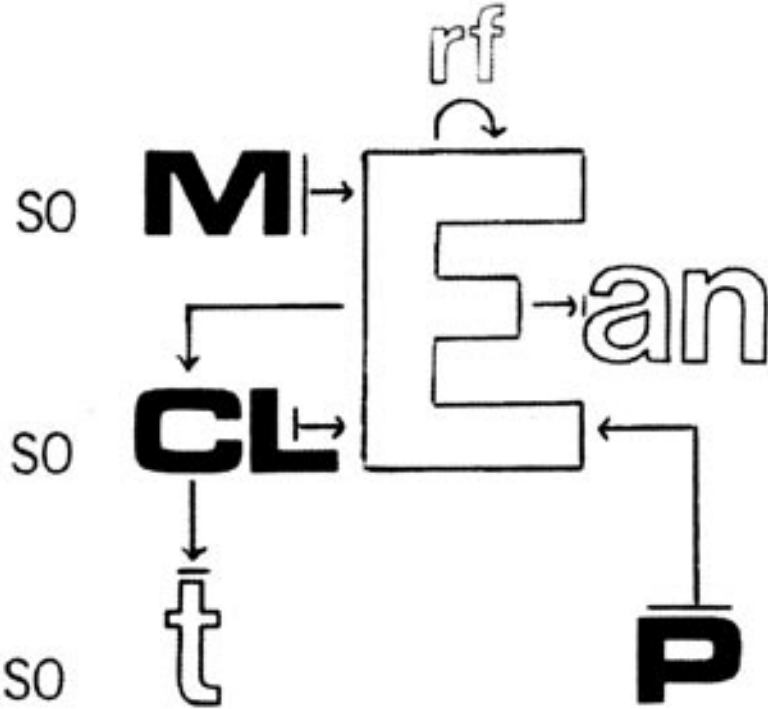

RAM

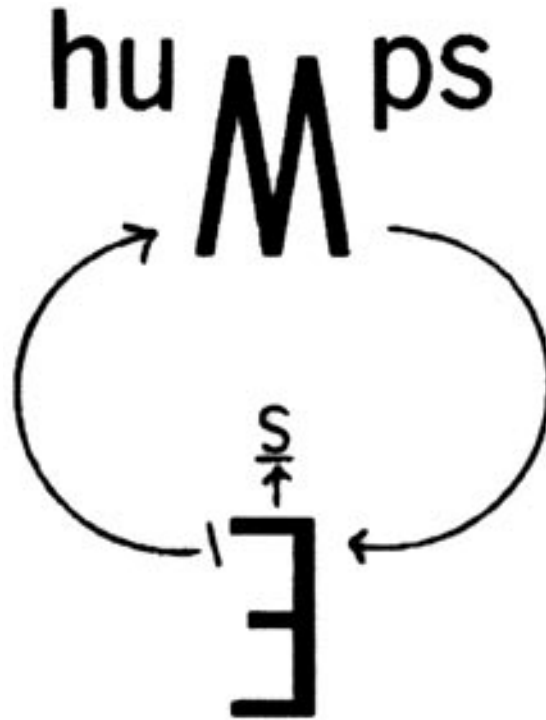

GOD

The

EAT

fro

in G

w
@
Ld

the

GOD THE FROG

EA
T'S
he
ing



I'M O.K. BUT



my **B** **A**^Hts IN
rn
V
E

HIS CHEST

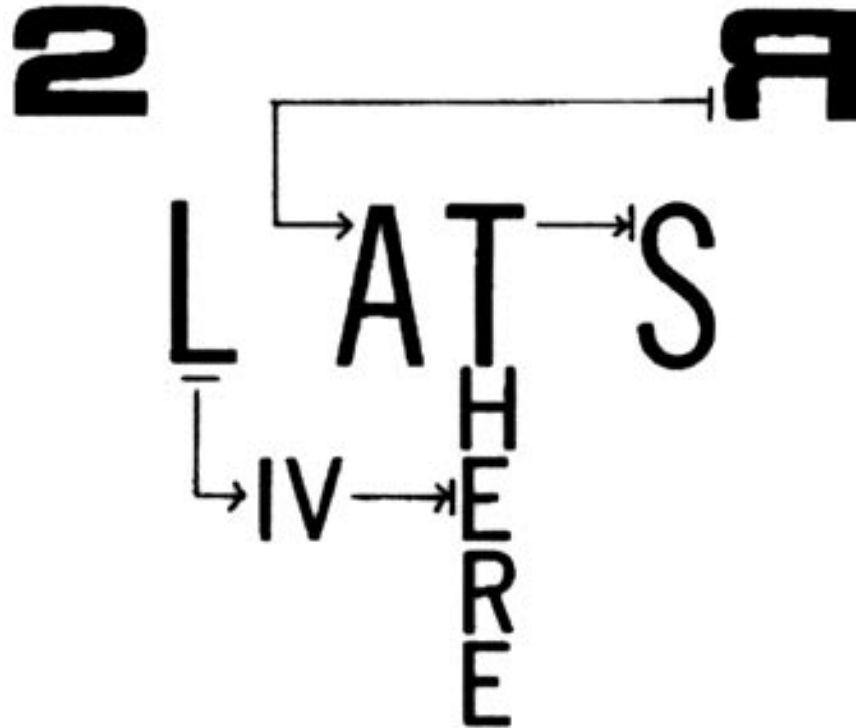

STARS

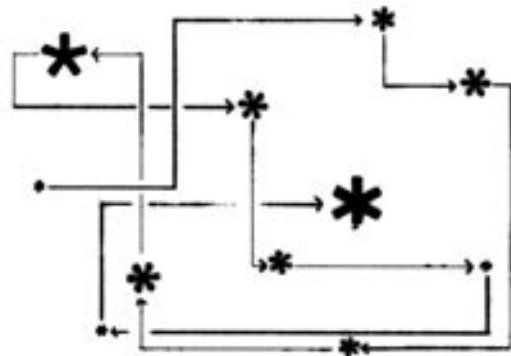

- * show people
- * MITED
- * FOXIE
- * PARTY
- * OWE
- * BOOR
- * SUCCESS
- * OUTA SIGHT
- * INVYED
- * WILDEST
- * OWIE
- * OWN



SEQUENCING by K.S. Ernst
Printed in the Autonomous Republic of Qazingulaza

The logo is contained within a light blue square with a black border. The square is filled with a pattern of small black dots and larger black oval shapes, some of which are arranged in vertical columns. The text 'XeXoXiaL' is written in a large, white, bold, sans-serif font with a black outline, and 'editions' is written in a smaller, white, sans-serif font with a black outline below it.

XeXoXiaL
editions